

## POLE MOUNTING

### STEP 1:

Take out the luminaire, Fix one end of the steel chain to the luminaire and the other hand onto the mounting bracket. keep the bracket aligned with the brace strut, tighten the screws by wrench. See Figure 5, 6.

### STEP 2:

Adjust the illumination angle of the whole lamp and single module to desired position by allen wrench. optional laser pen can be used to correct the direction of illumination. See Figure 7.

### STEP 3:

Connect the wires.

\*1 Allen wrench: 8mm  
\*2 Minimum M12 screws (Not provided)  
\*3 Screw nuts (Not provided)

## IMPORTANT

Check whether it concerns an AC(Alternating Current) based system - 100-240V/277V AC, 50/60Hz.

### ELECTRICAL CONNECTIONS - 100-240V/277V AC, 50/60Hz

#### PHASE TO NEUTRAL WIRING

## AC BASED

### STEP 1:

Make the following Electrical Connections:

- Connect **INPUT GROUND** conductor to **GREEN WIRE** position of the terminal block or **GROUND** conductor of LED driver.
- Connect **INPUT VOLTAGE** conductor to **BROWN WIRE** position of the terminal block or **LIVE** conductor of LED driver.
- Connect **INPUT NEUTRAL** conductor to **BLUE WIRE** position of the terminal block or **NEUTRAL** conductor of LED driver.

### STEP 2:

Make sure all the connection are correct.

### STEP 3:

If the fixture without a terminal block, please insulate all electrical connections with wire nuts suitable for at least 90°C.

Input cable should be at least H05RN-F 3x1.5mm<sup>2</sup>(SJTW 16AWG) or outdoor grade cable with rubber sheathed(not supplied). The cable must have a minimum cross sectional area of 1.5mm<sup>2</sup>(16AWG).

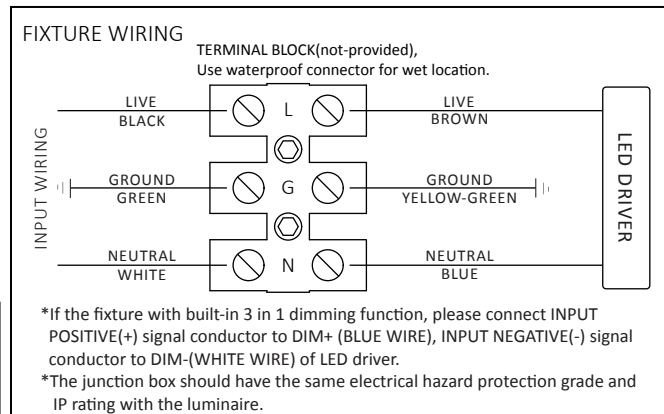

- To avoid the possibility of electrical shock, turn off power supply before installation or servicing. Installation and servicing should be performed by qualified personnel.
- Product must be installed in accordance with your local electrical code. If you are not familiar with these codes and requirements, consult a qualified electrician.
- Do not change the structure or any components of the fixture to ensure safety.
- Lock the installation angle after luminaire installed. As following figure.



This marking indicates that this product should not be disposed with other household wastes throughout the EU. To prevent possible harm to the environment or human health from uncontrolled waste disposal, recycle it responsibly to promote the sustainable reuse of material resources. To return your used device, please use the return and collection systems or contact the retailer where the product was purchased. They can take this product for environmental safe recycling.